

Olivehurst Public Utility District



Board Report

Meeting Date: January 19, 2023

Item description/summary:

Olivehurst Fire Departments ladder truck 317 is aging (30 years old) At the last mandatory third party yearly inspection ladder T317 narrowly passed. This review includes all ladders, pumps, and department of transportation (DOT) inspections. This is obviously a safety concern if we have a fire or emergency. Currently we are protecting Hard Rock with an eight story hotel, multiple two story apartment complexes' a very larger industrial track and are currently reviewing five prosed three story apartment complexes'. I'm recommending purchasing a new Demo Sutphen Ladder Truck with a platform. The unit proposed is a demonstrator/Stock unit currently in production. Note: A new "Spec" truck lead time is presently 40 Months.

Proposal Apparatus:

- Purchase of a new Demo aerial ladder truck with platform minimum 100 feet.
- Approximate cost of new ladder truck \$2 million

Fiscal Analysis:

See Financial Manager analysis report

Employee Feedback

Staff is very happy to see department looking at new ladder truck

Sample Motion:

Consider approving staff to move forward with purchasing a new Sutphen demo aerial ladder platform with fiscal analysis report by Financial Manager not to exceeded 2million dollars.

Prepared by:

Randy York Fire Chief

Olivehurst Public Utility District



Agenda Item Staff Report

Meeting Date: January 19, 2023

Item description/summary:

Purchase of new fire ladder truck

See Fire Staff Report

Fiscal Analysis:

The Fire Department has current obligations of \$ \$173,293 to the General Fund Administration Cash and \$400,000 to Boise Equipment for a Fire Engine Type Model 34 on order. The Fire Department's cash reserves alone are not sufficient for a \$2,000,000 expenditure and funding needs to be obtained from other sources. The attached analysis shows options on how to potentially find funding for this purchase.

Employee Feedback

Sample Motion:

Prepared by: Karin Helvey – Financial Manager

General Fund (11)

	Balance	Loan Amount	Maturity Date	Annual Payment	Repayment Source	From	
Pool (01) Liner	\$77,511.50	85,500.00	06/30/31	\$9,271.00	Property Tax Allocation	GF-Administration (00)	<i>Approved By Board 01/19/2022</i>
Fire (09) Command Vehicle	5,849.01	30,000.00	06/30/23	\$6,181.19	Property Tax Allocation/Prop 172/Strike Team	GF-Administration (00)	<i>Approved By Board 06/21/2018</i>
Fire (09)Engine #314	167,444.33	220,549.83	06/30/37	\$9,271.00		GF-Administration (00)	<i>Approved By Board 06/21/2018</i>

Wastewater (13) Capacity Fees

Water (12) USDA COP Payoff	\$786,423.73	1,158,330.51	06/30/34	\$70,637.37	Service Revenues		<i>Approved By Board 06/15/2017</i>
Water (12) Well #34 PLOG reimbursement	\$1,718,252.43	1,800,000.00	06/30/41	\$99,747.57	Future Water Capacity Fees		<i>Approved By Board 4/21/22</i>

Fire Department Commitments

Command Vehicle	5,849.01	To General Fund (Admin Cash)
Engine 314	167,444.33	To General Fund (Admin Cash)
Fire engine Type 3 Model 34	400,000.00	Boise Equipment (when completed - ordered 2021)
	573,293.34	
LADDER Truck	2,000,000	
	2,000,000.00	
Total Commitments	\$ 2,573,293	

Available Cash

1		400,000	Purchase of Fire Engine on Order
1	100,000		
2	150,000		
3	318,452		Purchase of Ladder Truck
4	50,000		
4	50,000		
	\$ 668,452	\$ 400,000	

Total Fire Cash Available **\$ 1,068,452**

Cash Needed to purchase Ladder Truck **\$ 2,000,000-668,452 = \$ 1,331,548**

	1,331,548	Cash needed
GF Deb Consolidation	173,293	GF Debt Consolidation
New Interfund Advance	\$1,504,841	

Funding Source Options

Option	Amount	Funding Source	Comments
A	\$1.5 Mill	General Fund Admin Loan	Depletes GF reserves and potential funding for Pool and Olivehurst Parks
	\$ 668 K	From Fire Department Reserves	Depletes Fire Department reserves
B		Interfund Advance from Wastewater Cap Fees	
C		Funding from Hard Rock	
D		Combination of A and B	
E		Obtain outside financing	

Annual Repayment

Amount	Funding Source	Comments
\$1,505,000 2% 20 Years	\$92,040.86	Annual True-up Hard Rock
\$2,000,000 2% 20 Years	\$122,313.44	Property Tax Allocation Prop
\$1,505,000 3% 20 Years	\$101,159.64	172 receipts
\$2,000,000 3% 20 Years	\$134,431.42	

Fire

		September 2022	Available		
Unrestricted	Operating Cash	561,075	561,075		
Unrestricted	Engine Rental - Strike Team Reimbursement	602,478	602,478	500,000	1
Reserved	Capital Outlay Expenditures	150,000	150,000	150,000	2
Reserved	Future Unemployment Expense				
Reserved	Vehicle Replacement				
Reserved	Reserve for Depreciation	79,854	79,854		
Reserved	In Lieu Fees - ER	281,859	318,452	318,452	3
Restricted	Measure K	635,050	176,738	50,000	4
Restricted	Fire Mitigation Fees	198,548	198,548	50,000	5

Administration

Unrestricted	Operating Cash	1,848,731	1,848,731	1,848,731	A
Reserved	Unallocated Cash	228,490	228,490	228,490	A
Reserved	Due to Park Fund 33 /Unallocated Cash	754,945			
Reserved	Reserve for Depreciation	432,431	432,431	432,431	A
Reserved	Compensated Absences-all Departments	259,060			
Restricted	Advance Payments	21,233			
Restricted	Customer Deposits	19,832			
Restricted	Developer Deposits	33,442			
Restricted	Developer Deposits (Plumas Lake)	688,918			

Waste Water

Unrestricted	Operating Cash	2,757,408			
Unrestricted	Operating Reserve (6 month operating expenses)				
Reserved	Reserve for Depreciation	2,500,000			
Reserved	Reserve for Capital Replacement	2,395,379			
Restricted - CAP Fees - Adn	WWTF CAP FEES - Admin Share	893,122			
Restricted - CAP Fees	WWTF CAP FEES - ALL - YUBA COUNTY CASH	8,066,909	8,066,909	8,066,909	B
Restricted - CAP Fees	SWR COLLECT SYS FEES - NPL - YUBA COUNTY CASH	813,267			
Restricted - CAP Fees	SWR COLLECT SYS - SPL - YUBA COUNTY CASH	686,267			
Restricted - CAP Fees	SWR COLLECT SYS - HOH - YUBA COUNTY CASH	625,825			

OLIVEHURST PUBLIC UTILITY DISTRICT

Intrafund Advances

Ladder Truck Finance Options

Loan Date:	07/01/2022	2,000,000.00	Term	Rate
			20	2.00%
			Annual	
			Payment	(\$122,313.44)

	Date	Payment	Interest	Principal	Balance
1	1-Jul-23	\$122,313.44	\$40,000.00	\$82,313.44	\$1,917,686.56
2	1-Jul-24	122,313.44	38,353.73	83,959.70	1,833,726.86
3	1-Jul-25	122,313.44	36,674.54	85,638.90	1,748,087.96
4	1-Jul-26	122,313.44	34,961.76	87,351.68	1,660,736.28
5	1-Jul-27	122,313.44	33,214.73	89,098.71	1,571,637.57
6	1-Jul-28	122,313.44	31,432.75	90,880.68	1,480,756.89
7	1-Jul-29	122,313.44	29,615.14	92,698.30	1,388,058.59
8	1-Jul-30	122,313.44	27,761.17	94,552.26	1,293,506.32
9	1-Jul-31	122,313.44	25,870.13	96,443.31	1,197,063.01
10	1-Jul-32	122,313.44	23,941.26	98,372.18	1,098,690.84
11	1-Jul-33	122,313.44	21,973.82	100,339.62	998,351.22
12	1-Jul-34	122,313.44	19,967.02	102,346.41	896,004.81
13	1-Jul-35	122,313.44	17,920.10	104,393.34	791,611.47
14	1-Jul-36	122,313.44	15,832.23	106,481.21	685,130.26
15	1-Jul-37	122,313.44	13,702.61	108,610.83	576,519.43
16	1-Jul-38	122,313.44	11,530.39	110,783.05	465,736.38
17	1-Jul-39	122,313.44	9,314.73	112,998.71	352,737.67
18	1-Jul-40	122,313.44	7,054.75	115,258.68	237,478.99
19	1-Jul-41	122,313.44	4,749.58	117,563.86	119,915.13
20	1-Jul-42	122,313.44	2,398.30	119,915.13	(0.00)

Loan Date:	07/01/2022	1,505,000.00	Term	Rate
			20	2.00%
			Annual	
			Payment	(\$92,040.86)

	Date	Payment	Interest	Principal	Balance
1	1-Jul-23	\$92,040.86	\$30,100.00	\$61,940.86	\$1,443,059.14
2	1-Jul-24	92,040.86	28,861.18	63,179.68	1,379,879.46
3	1-Jul-25	92,040.86	27,597.59	64,443.27	1,315,436.19
4	1-Jul-26	92,040.86	26,308.72	65,732.14	1,249,704.05
5	1-Jul-27	92,040.86	24,994.08	67,046.78	1,182,657.27
6	1-Jul-28	92,040.86	23,653.15	68,387.72	1,114,269.56
7	1-Jul-29	92,040.86	22,285.39	69,755.47	1,044,514.09
8	1-Jul-30	92,040.86	20,890.28	71,150.58	973,363.51
9	1-Jul-31	92,040.86	19,467.27	72,573.59	900,789.92
10	1-Jul-32	92,040.86	18,015.80	74,025.06	826,764.86
11	1-Jul-33	92,040.86	16,535.30	75,505.56	751,259.29
12	1-Jul-34	92,040.86	15,025.19	77,015.67	674,243.62
13	1-Jul-35	92,040.86	13,484.87	78,555.99	595,687.63
14	1-Jul-36	92,040.86	11,913.75	80,127.11	515,560.52
15	1-Jul-37	92,040.86	10,311.21	81,729.65	433,830.87
16	1-Jul-38	92,040.86	8,676.62	83,364.24	350,466.63
17	1-Jul-39	92,040.86	7,009.33	85,031.53	265,435.10
18	1-Jul-40	92,040.86	5,308.70	86,732.16	178,702.94
19	1-Jul-41	92,040.86	3,574.06	88,466.80	90,236.14
20	1-Jul-42	92,040.86	1,804.72	90,236.14	0.00

OLIVEHURST PUBLIC UTILITY DISTRICT

Ladder Truck Finance Options

Loan Date:	07/01/2022	1,505,000.00	Term	Rate
			20	3.00%
			Annual	
			Payment	(\$101,159.64)

	Date	Payment	Interest	Principal	Balance
1	1-Jul-23	\$101,159.64	\$45,150.00	\$56,009.64	\$1,448,990.36
2	1-Jul-24	101,159.64	43,469.71	57,689.93	1,391,300.43
3	1-Jul-25	101,159.64	41,739.01	59,420.63	1,331,879.80
4	1-Jul-26	101,159.64	39,956.39	61,203.25	1,270,676.56
5	1-Jul-27	101,159.64	38,120.30	63,039.34	1,207,637.21
6	1-Jul-28	101,159.64	36,229.12	64,930.52	1,142,706.69
7	1-Jul-29	101,159.64	34,281.20	66,878.44	1,075,828.25
8	1-Jul-30	101,159.64	32,274.85	68,884.79	1,006,943.46
9	1-Jul-31	101,159.64	30,208.30	70,951.34	935,992.12
10	1-Jul-32	101,159.64	28,079.76	73,079.88	862,912.25
11	1-Jul-33	101,159.64	25,887.37	75,272.27	787,639.98
12	1-Jul-34	101,159.64	23,629.20	77,530.44	710,109.53
13	1-Jul-35	101,159.64	21,303.29	79,856.35	630,253.18
14	1-Jul-36	101,159.64	18,907.60	82,252.04	548,001.14
15	1-Jul-37	101,159.64	16,440.03	84,719.61	463,281.53
16	1-Jul-38	101,159.64	13,898.45	87,261.19	376,020.34
17	1-Jul-39	101,159.64	11,280.61	89,879.03	286,141.31
18	1-Jul-40	101,159.64	8,584.24	92,575.40	193,565.91
19	1-Jul-41	101,159.64	5,806.98	95,352.66	98,213.24
20	1-Jul-42	101,159.64	2,946.40	98,213.24	0.00

Loan Date:	07/01/2022	2,000,000.00	Term	Rate
			20	3.00%
			Annual	
			Payment	(\$134,431.42)

	Date	Payment	Interest	Principal	Balance
1	1-Jul-23	\$134,431.42	\$60,000.00	\$74,431.42	\$1,925,568.58
2	1-Jul-24	134,431.42	57,767.06	76,664.36	1,848,904.23
3	1-Jul-25	134,431.42	55,467.13	78,964.29	1,769,939.94
4	1-Jul-26	134,431.42	53,098.20	81,333.22	1,688,606.72
5	1-Jul-27	134,431.42	50,658.20	83,773.21	1,604,833.51
6	1-Jul-28	134,431.42	48,145.01	86,286.41	1,518,547.10
7	1-Jul-29	134,431.42	45,556.41	88,875.00	1,429,672.10
8	1-Jul-30	134,431.42	42,890.16	91,541.25	1,338,130.84
9	1-Jul-31	134,431.42	40,143.93	94,287.49	1,243,843.35
10	1-Jul-32	134,431.42	37,315.30	97,116.11	1,146,727.24
11	1-Jul-33	134,431.42	34,401.82	100,029.60	1,046,697.64
12	1-Jul-34	134,431.42	31,400.93	103,030.49	943,667.16
13	1-Jul-35	134,431.42	28,310.01	106,121.40	837,545.75
14	1-Jul-36	134,431.42	25,126.37	109,305.04	728,240.71
15	1-Jul-37	134,431.42	21,847.22	112,584.19	615,656.52
16	1-Jul-38	134,431.42	18,469.70	115,961.72	499,694.80
17	1-Jul-39	134,431.42	14,990.84	119,440.57	380,254.23
18	1-Jul-40	134,431.42	11,407.63	123,023.79	257,230.44
19	1-Jul-41	134,431.42	7,716.91	126,714.50	130,515.94
20	1-Jul-42	134,431.42	3,915.48	130,515.94	0.00



OLIVEHURST PUBLIC UTILITY DISTRICT

1970 9th Avenue, Olivehurst CA 95961
(530) 743 4657 Fax (530) 743 4657

DATE

Vendor

BOISE MOBILE EQUIPMENT

5656 W. Morris Hill Road

Boise, ID 83706

800-445-8342 208-338-1444

FOR _____

Fire Engine Type 3, Model 34 Tag-on

State Contract No. 1-17-23-21B, Supp 10

Details

Fire Engine Type 3, Model 34 Tag-on

AMOUNT

364,209.23

SUBTOTAL **\$364,209.23**

TAX **estimated included**

OTHER

TOTAL **\$364,209.23**

Site Information:

Olivehurst Public Utility District Fire Department

Randy York, ryork@opud.org (530) 788-2557

1962 9th Avenue

Olivehurst, CA 95961

Approved by: _____

Karin Helvey, Finance Manager



PROPOSAL

TO THE:

Olivehurst Fire Department
1962 9th Street
Olivehurst, CA 95961

DATE: October 1, 2022

We hereby propose and agree to furnish the following firefighting equipment upon your acceptance of this proposal:

One (1) Sutphen Model SPH100 Aerial Platform Complete and Delivered for the Total Sum of:	\$1,737,439.79
Tax @ 8.25%	\$143,338.78

Fire Department Travel:

The cost associated with inspections of the apparatus can be added. Cost is per person per trip.....\$2,200.00 Ea.

The unit proposed is a demonstrator/Stock unit currently in production. It is being manufactured completely in accordance with the following proposal and the projected delivery will be January 2024 Demonstrator/Stock unit are sold on a first come basis. The unit is subject to delays from all causes beyond our control.

Note: A new "Spec" truck lead time is presently 29 Months

This proposal price is based the Sutphen Corporation's Cooperative Purchasing Contract (#PS20250) with National Purchasing Partners/Oregon League of Cities. The proposed price is valid for up to 30 days from the date of this proposal. If the contract or purchase order is not received within this proposed duration, we reserve the right to extend, withdraw, or modify our proposal, including pricing, delivery times, and prepayment discounts as applicable.

Respectfully submitted,

Travis Pistoichini

Travis Pistoichini
Republic Fire Equipment LLC (CA Dealer #03868)
Authorized Representative for Sutphen Corporation
570-527-6621

SUTPHEN CORPORATION

6450 Eiterman Road | Dublin, OH 43016 | 1-800-848-5860

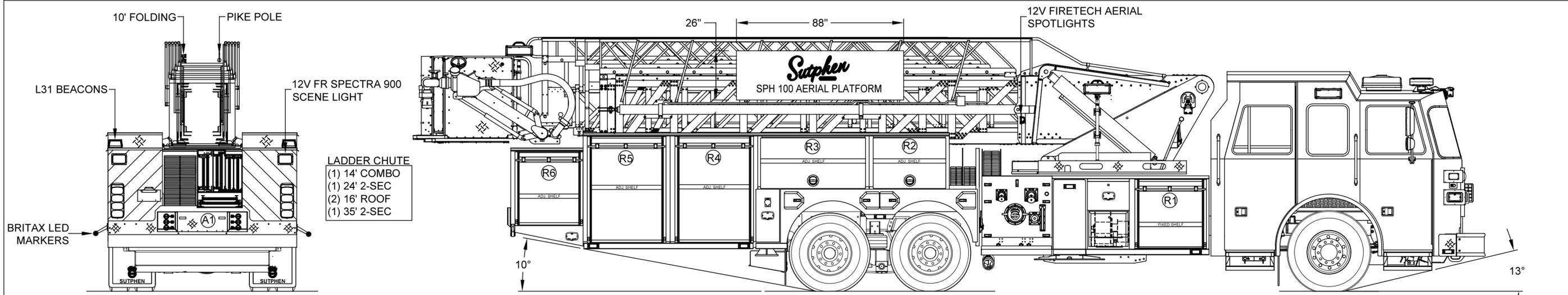

LADDER CHUTE
 (1) 14' COMBO
 (1) 24' 2-SEC
 (2) 16' ROOF
 (1) 35' 2-SEC

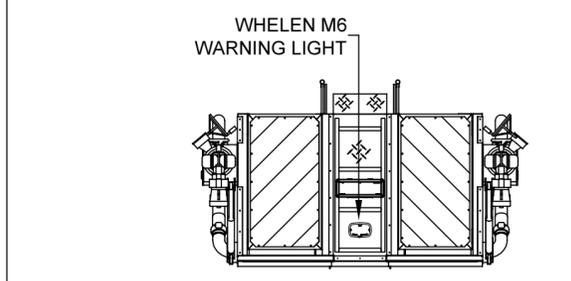

TWO TONE CAB
 WHITE OVER RED
 PAINT BREAK #1

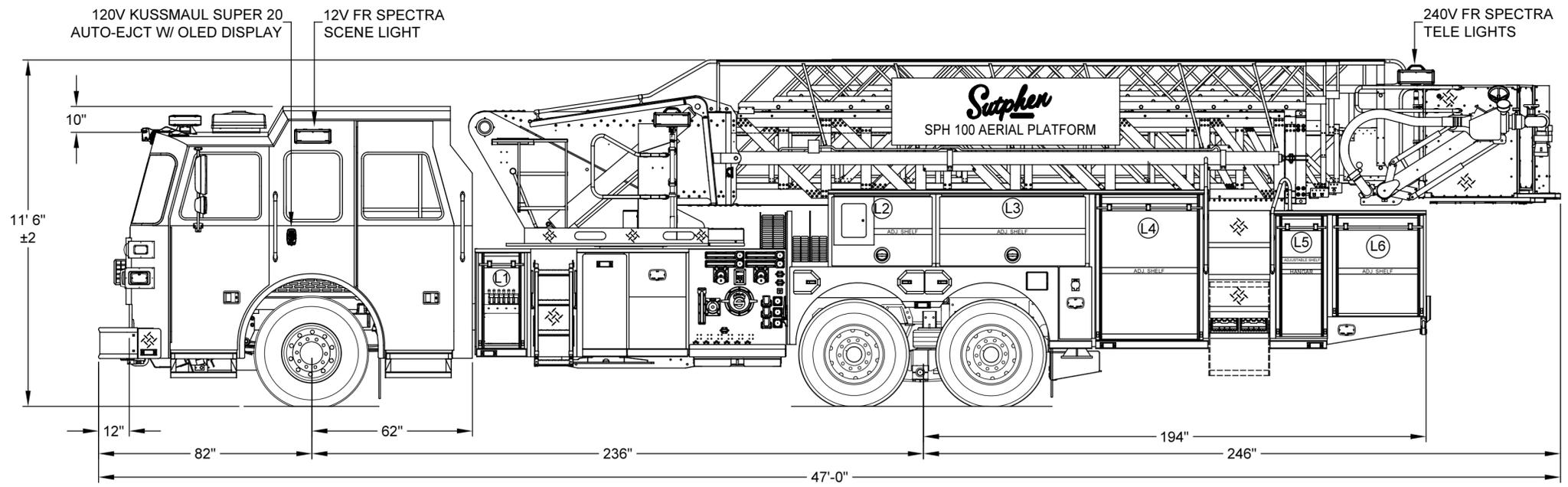
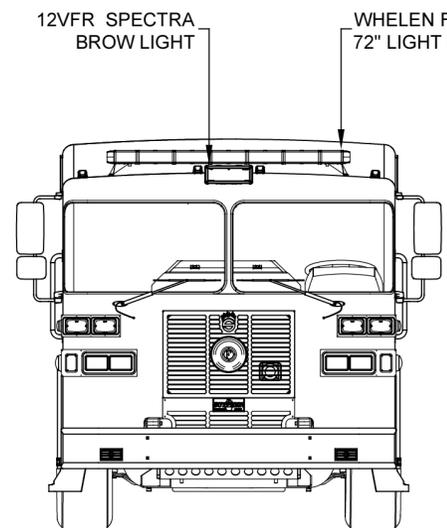
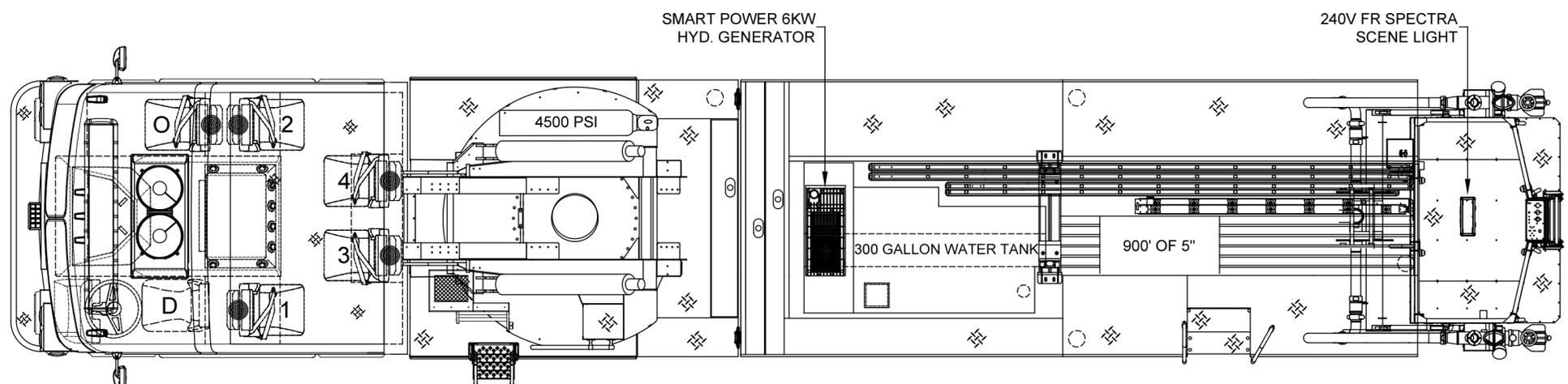

DOOR OPENINGS		
COMPT.	HEIGHT	WIDTH
L1	31 13/16	13 7/16
L2	23	33 1/4
L3	23	50 1/4
L4	48 1/2	38 3/4
L6	32	53

COMPARTMENT DIMENSIONS		
HEIGHT	WIDTH	DEPTH
38 1/2	20 5/16	19 7/8
27 1/2	41 1/2	12 1/8
27 1/2	58	12 1/8
56 1/2	45 3/4	26 1/2
40	59	26 1/2

DOOR OPENINGS		
COMPT.	HEIGHT	WIDTH
R1	31 13/16	33 7/16
R2	23	33 1/4
R3	23	50 1/4
R4	48 1/2	38 3/4
R5	48 1/2	38 3/4
R6	32 1/8	30 7/8

COMPARTMENT DIMENSIONS		
HEIGHT	WIDTH	DEPTH
38 1/2	40	8 1/2 LOWER 10\"/>
27 1/2	41 1/2	26 1/2
27 1/2	58	26 1/2
56 1/2	45 3/4	26 1/2
56 1/2	45 3/4	26 1/2
40 1/8	34 3/4	26 1/2

DOOR OPENINGS		
COMPT.	HEIGHT	WIDTH
A1	9 1/8	24 1/2

COMPARTMENT DIMENSIONS		
HEIGHT	WIDTH	DEPTH
9 7/8	26	88

TOTAL COMPARTMENT VOLUME - 283.49 CU.FT.

DIMENSIONS SHOWN ON THIS DRAWING ARE APPROXIMATE AND ARE SUBJECT TO MINOR DEVIATIONS DURING CONSTRUCTION.

IN THE EVENT OF A DISCREPANCY BETWEEN THE SUTPHEN SPECIFICATIONS AND DRAWING, THE SUTPHEN SPECIFICATIONS SHALL PREVAIL.

DRAWING IS FOR REFERENCE ONLY. SOME ITEMS PROPOSED MAY NOT BE SHOWN OR NOTED.

CUSTOMER APPROVAL

NAME: _____

TITLE: _____

DATE: _____

REV.	DESCRIPTION	BY	DATE
A	REV-A SHOP ORDER	JML	06/16/2022

DRAWN BY: K.EXEL

DATE: 5/13/2022

MFG. FACILITY: DUBLIN

DEMO 540

SPH100 AERIAL PLATFORM

DWG. NO.: HS-7553



Sutphen
Component Report
 Dealership: Sutphen Corporation

HS-7553 Demo 540 (SPH100)

Order#: SOB003373
 Contact: Keith Exel
 Position: STM
 Phone: 614-354-4854
 Mobile:
 Email: keith.exel@sutphencorp.com

Bill To	Ship To
Customer: Sutphen Corporation Contact: Keith Exel, STM Address: PO Box 158 Amlin, OH 43002	Customer: Sutphen Corporation Contact: Keith Exel, STM Address: 6450 Eiterman Rd. Dublin, OH 43016

Comments
Project Coordinator: Johnathon Lambert Sales Person: Keith Exel Revision Level: **REV-A** Truck Type: SPH100 Body Facility: Dublin

Line	Item #	Qty	Item Description/Comments
1		1	**ENG Facility = Dublin.
2		1	**ENG Pump Module Series = Customized Module.
3		1	**ENG Electrical System = Point-to-Point.
4	10000215	1	STD WIRING SCHEMATIC
5	10001200	1	MAXIMUM APPARATUS HEIGHT = N/A
6		1	**ENG Overall Apparatus Height = 11' 6" +/- 2".
7	10001220	1	MAXIMUM APPARATUS LENGTH = N/A
8		1	**ENG Overall Apparatus Length = 47' 0" +/- 2".
CHASSIS			
9	10010006	1	CHASSIS, CUSTOM
10	51070236	1	WHEELBASE = 236"
11		1	**ENG AF Number = 184".
12	25020120	1	FRAME, 10" DOUBLE RAILS, DOMEX, TANDEM AXLE - AERIAL (110K PSI)
13	45010001	1	FRONT TOW EYES, BELOW BUMPER, PAINTED

Line	Item #	Qty	Item Description/Comments
14		1	**ENG Painted Frame Color Black.
15	46010000	1	REAR TOW EYES, PAINTED
16		1	**ENG Painted Frame Color Black.
17	40010250	1	STEERING - ROSS TAS-85
18	22010100	1	DRIVE LINE, SPICER, 1810 SERIES (Tandem)
19	23014230	1	ENGINE, CUMMINS X 12 500HP DOC-DPF-DEF-SCR OBD
20	23029200	1	ENGINE WARRANTY, 5 YEAR, 100,000 MILES FOR CUMMINS X12 / X15
21	23029400	1	AFTERTREATMENT WARRANTY, 5 YEAR, 100,000 MILES FOR CUMMINS X12 / X15
22	23030006	1	AIR INTAKE/EMBER SEPARATOR
23	23031176	1	FUEL FILTER/WATER SEPARATOR, PRIMARY, FLEETGUARD FUEL PRO FH230
24	23031220	1	FUEL FILTER, SECONDARY, FLEETGUARD, FF5825NN
25	47012440	1	TRANSMISSION, ALLISON GEN 5, EVS4000
26		1	**CLAR NOTES, -AX Item Number for Generator PTO: 10137646 -AX Item Number for Extension Shaft: 10137656. -AX Item Number for Aerial PTO: 10137647. -PTO AX Numbers are being drive from Standard Spreadsheet (these won't be accurate in the case of special circumstances).
27	23110000	1	JACOBS ENGINE BRAKE
28	47024050	1	TRANSMISSION COOLER
29	47030000	1	ALLISON TOUCH PAD SHIFTER
30		1	**ENG Shifter Pad Gearing = 5 Gears open, 6th Gear locked, Mode Button for Generator.
31	21021200	1	COOLING SYSTEM
32	21030195	1	COOLANT FILTER
33	21030000	1	FAN CLUTCH
34	21030200	1	RADIATOR COOLANT RECOVERY, PRESSURIZED SYST
35	26020100	1	FUEL BEAM, 65 GALLON (AERIALS)
36	26030000	1	FUEL FILL
37	26030100	1	FUEL COOLER

Line	Item #	Qty	Item Description/Comments
38	24040000	1	DIESEL EXHAUST FLUID TANK
39		1	**ENG DEF Access = Hinged Door for DEF Access.
40	13010225	1	ALTERNATOR, LEECE NEVILLE 420 AMP BLP4003
41	13030100	1	LOW VOLTAGE ALARM, FLOYD BELL TXB-V86-515-QF
42	15010500	1	BATTERIES, INTERSTATE TYPE 31 MHD (4)
43	15031700	1	BATTERY JUMPER TERMINALS
44	15038888	1	SPECIAL ITEM, BATTERY CHARGER, KUSSMAUL CHIEF 4012
45	15038888	1	SPECIAL ITEM, 120V SHORELINE INLET, KUSSMAUL SUPER 20 AUTO EJECT W/ OLED DISPLAY
46		1	**CLAR NOTES, -Shoreline Inlet Location = Driver's side of Cab, standard location. -Shoreline Cover Color = Red.
47	14022130	1	FRONT AXLE, HENDRICKSON STEERTEK NXT 23,000 LB.
48	41022130	1	FRONT SUSPENSION, HENDRICKSON 23,000 LBS. (4) 56" LEAFS
49	41040100	1	FRONT SUSPENSION LOCKING CYLINDERS, AERIAL TOWER
50	41040200	1	FRONT SUSPENSION LOCKOUT PLATE
51	41040510	1	STEER ASSIST
52	43010370	1	FRONT TIRES MICHELIN 425/65R22.5 LRL XFE 22.5 X 12.25 WHEELS
53	14520310	1	REAR AXLE, MERITOR RT-50-180 52,000 LB TANDEM
54		1	**CLAR NOTES, -Sales is requesting a temporary top speed of 68 MPH while the truck demo's. -This will need to be reduced back to 60 MPH once this unit is sold to a customer. -Rear axle gear ratios and transmission gearing will need to be selected and set accordingly.
55	14530150	1	TOP SPEED, 60 MPH
56	42020025	1	REAR SUSPENSION, LINK, AIR LIFT, 52,000 LBS. AIR RIDE
57	44020270	1	TIRES, REAR, MICHELIN 12R22.5 LRH XZE HIGHWAY 52,000 GVWR
58	42920300	1	TIRE PRESSURE MONITOR, QUICK PRESSURE
59	44220100	1	WHEELS, ALUM, ACCURIDE (MAX 58K REAR)
60	44270105	1	HUB COVERS, FRONT & REAR, POLISHED STS (TANDEM AXLE)
61	44270305	1	CHROME LUG NUT CAPS, FRONT & REAR (TANDEM AXLE)

Line	Item #	Qty	Item Description/Comments
62	44271100	1	MUD FLAPS, FRONT (PAIR)
63	44271200	1	MUD FLAPS, REAR (PAIR)
64	54010010	1	DATA, SAFETY & WARNING TAGS APPLICATION, ADHESIVE
65	16010009	1	BRAKES MERITOR SCAM 6" FRONT, SCAM 7" REAR
66	18030605	1	UNITED SAFETY VEHICLE BRAKE LOCK SYSTEM
67		1	<p>**CLAR NOTES,</p> <ul style="list-style-type: none"> -Brake Lock System Keypad Code = 1890. -Keypad mounted in Lower Console Position 3. -Emergency switch mounted in Lower Console Position 4, top left corner. -Reference HS-6940 Demo 501. -See Reference Photo #01 on Shared Drive.
68		1	
69	18010046	1	AIR BRAKE SYST 6 TANKS WABCO 1200 DRYER (TANDEM)
70	18030140	1	AIR INLET CONNECTION
71		1	**ENG Standard Air Inlet Location = Left hand side of Driver's step well.
72	18035110	1	AIR COMPRESSOR, KUSSMAUL AUTO PUMP AC, 100PSI
73	18220500	1	NO ELEC STABILITY CONTROL SYS
74	18110100	1	WABCO 6 CHANNEL ANTI-LOCK BRAKES (TANDEM)
75	54010200	1	AERIAL CHASSIS PREP (TANDEM AXLE)
76	53510000	1	COMPRESSION FITTINGS ON AIR SYSTEM (CHASSIS)
77	54010000	1	MISCELLANEOUS ITEMS ON CHASSIS
CAB			
78	11024292	1	CAB TSAL4SK 62" 10" RR 1/2
79	11030025	1	CAB CERTIFICATION - STRUCTURAL INTEGRITY
80	11030950	1	CAB LOCKDOWN LATCHES

Line	Item #	Qty	Item Description/Comments
81	11031025	1	CAB TILT SYSTEM, AIR CONTROL VALVE
82	11031100	1	MANUAL BACK-UP TILT SYSTEM
83		1	**CLAR NOTES, -Cab Tilt Controls = Officer's side, behind Outrigger access panel. -Cab Tilt Controls to be installed on a bracket behind Outrigger access panel door. -Label door to show location of controls.
84	11031350	1	CAB DOORS, FULL LENGTH (4)
85	11031398	1	SPECIAL ITEM, SUTPHEN "S", CAB DOOR PUDDLE LIGHTS (PAIR) (2)
86		1	**CLAR NOTES, -Puddle lights to be installed on all Cab doors. -Puddle lights to come on when Cab door is opened.
87	11031385	1	CAB STEPS, LOWER GRIP STRUT, INTERMEDIATE DIAMONDPLATE
88	11031390	1	AUXILIARY CAB STEPS, ALUM, GRIP STRUT (SET OF 4)
89	11031421	1	CAB DOOR WINDOWS, POWER (4)
90	11031401	1	CAB SIDE WINDOWS, FIXED, BOTH SIDES
91	11031445	1	TWO FIXED WINDOWS IN BACK WALL OF CAB APPROX 11.25" X 5.25" OVAL
92	11031465	1	WINDOW TINTING (LIMO TINT 8%) - EACH (6)
93	52010010	1	ELECTRIC INTERMITTENT WIPERS
94	52030100	1	DEACTIVATE WINDSHIELD WIPERS WITH PARKING BRAKE ENGAGED
95		1	**ENG Override Switch to Re-Engage Wipers = Yes.
96	52030200	1	WINDSHIELD WASHER RESERVOIR
97	38010020	1	MIRRORS LANG MEKRA 300 SERIES HEATED & REMOTE
98	11024405	1	UPPER GRILLE, LEVEL STYLE FACADE (X12/X15)
99	11024510	1	FLAMING "S" LOGO, UPPER GRILLE, ILLUMINATED RED
100	11024605	1	LOWER GRILLE, POLISHED STAINLESS (X12/X15)
101	20010075	1	BUMPER, 12" POLISHED STAINLESS STEEL
102		1	**ENG Siren Speaker Perforations = No Speaker Perforations in Bumper.
103	20029800	1	BUMPER SIDES, DIAMONDPLATE
104	12010500	1	AIR HORNS, DUAL, GROVER #2040 RECTANGULAR

Line	Item #	Qty	Item Description/Comments
105		1	**ENG Air Horns Location: Outboard, (1) each side.
106	12030015	1	AIR HORNS CUTOUPS IN BUMPER, BEHIND PERFORATIONS (X12/X15 STYLE)
107	12030350	1	LANYARD CONTROL FOR AIR HORNS
108	12510110	1	ELEC SIREN, WHELEN 295HFS2, REMOTE FLUSH MOUNT
109		1	**ENG Siren Control Head Mounted in Lower Console Position 3.
110	12620100	1	SIREN SPEAKER, 100W, CAST PRODUCTS, SA4201-6B-A
111	12670110	1	SIREN SPEAKER(S) INSTALLED BEHIND CAB GRILLE
112	12710100	1	SIREN, FEDERAL Q2B, GRILLE MOUNT
113	12730205	1	MECH SIREN WIRED TO STEERING WHEEL BUTTON
114		1	**ENG Switch in Cab, Lower Console Position 2, "E Horn/Mech Siren".
115	12730350	1	MOMENTARY SWITCH ON DASH, OFFICER'S SIDE, FOR MECH SIREN
116		1	**ENG Switched in Cab, Lower Console Position 5, "Mech Siren".
117	12730363	1	SIREN BRAKE SWITCH FOR MECH SIREN, DRIVER'S & OFFICER'S SIDE
118		1	**CLAR NOTES, -Driver's switch switched in Cab, Lower Console Position 2, "Siren Brake". -Officer's switch switched in Cab, Lower Console Position 5, "Siren Brake".
119	32520520	1	HEADLIGHTS, LED, FIRETECH FT-4X6, DUAL STS HOUSINGS
120		1	**ENG Headlight Interior Finish = Chrome.
121	48010300	1	FRONT TURN SIGNALS, WHELEN 400 SERIES LED (4)
122	32530750	1	ICC LIGHTS, LED, ROOF MOUNTED MARKERS, GROTE
123	27022120	1	HANDRAILS, CAB EXTERIOR, KNURLED STAINLESS STEEL (4) SIDE
124	27025000	1	HANDRAILS, CAB INTERIOR, BLACK RUBBER COATED (2) FRONT ENTRY
125	27030120	1	HANDRAILS, REAR CAB INTERIOR DOOR, BLACK RUBBERIZED (2) AND KNURLED STS AT WINDOW (2)
126	11035405	1	DIAMONDPLATE REAR EXTERIOR WALL OF CAB (AERIAL OR TOP MOUNT)
127	11033250	1	UNDERCOATING, INTERIOR CAB DOORS
128	11035422	1	DIAMONDPLATE CAB ROOF 56" x FULL WIDTH
129	31010250	1	INTERIOR, MULTISPEC BLACK SPECKLE PAINT W/BLACK EMBOSSED FRP BOARD

Line	Item #	Qty	Item Description/Comments
130	11032929	1	DOOR PANEL, FULL STS
131	11032958	1	REFLECTIVE MATL, INTERIOR CAB DOORS, CHEVRONS, REFLEXITE
132		1	**CLAR NOTES, -Reflective Striping Color = #030 Red Transparent & #L2 Fluorescent Lime. -Reflective Striping Verbiage = "SUTPHEN".
133	31010291	1	CAB INTERIOR FLOOR COVERING, BLACK RUBBERIZED
134	22510100	1	ENGINE ENCLOSURE, FULL LENGTH
135	22510530	1	ENGINE ENCLOSURE COVERING, SCORPION BLACK URETHANE BLEND
136	11031670	1	TOOL MOUNTING PLATE, TOP OF ENGINE ENCLOSURE, NOT PROVIDED
137	11031680	1	CENTER CONSOLE W/MAP BOOK STORAGE, TOP OF ENGINE ENCLOSURE
138	22610050	1	ENGINE HOOD LIGHT, LED (1)
139	11031510	1	FLAT WORK SURFACE IN LIEU OF GLOVE BOX
140	11031710	1	UPPER CREW DOOR AREA, SMOOTH PANEL
141	29810100	1	CHASSIS ELECTRICAL DESCRIPTION
142	30010135	1	INSTRUMENTATION, AMETEK W/ CENTER & OVERHEAD CONSOLES (AERIALS)
			<p>Upper Command Console:</p> 
143		1	**ENG Overhead Console Panel's Finish: Black Wrinkle.
144		1	**ENG Overhead Console Position 1: Switch #1: Master Emergency. Switch #2: Front Scene. Switch #3: Left Scene. Switch #4: Right Scene. Switch #5: Rear Scene. Switch #6: Blank. Switch #7: Blank. Switch #8: Blank. Switch #9: Blank. Switch #10: Blank.
145		1	**ENG Overhead Console Position 2: -HD Jensen Stereo.
146		1	**ENG Overhead Console Position 3:

Line	Item #	Qty	Item Description/Comments
			-HVAC Controls.
147		1	**ENG Overhead Console Position 4: -Warning Indicators. -Seat Belt Monitor. -Lanyard Controls.
148		1	**ENG Overhead Console Position 5: -Blank.
149		1	**ENG Overhead Console Position 6: -Blank.
150		1	**ENG Overhead Console Position 7: -Blank.
151	30010500	1	LOWER COMMAND CONSOLE, L9 & X12
			<p>Lower Command Console (9L & 12L engines):</p>
152		1	**ENG Lower Command Console Finish: Black Urethane.
153		1	**ENG Lower Console Panel's Finish: Black Wrinkle.
154		1	**ENG Lower Console Position 1: -Transmission Shift Pad. -Pump Shift.
155		1	**ENG Lower Console Position 2: Switch #1: Jake On/Off. Switch #2: Low/Med/High. Switch #3: High Idle. Switch #4: PTO Lad/Jack. Switch #5: E Horn / Mech Siren Selector. Switch #6: Siren Brake. Switch #7: Blank.
156		1	**REV-A** **ENG Lower Console Position 3: -Parking Brake. -United Safety Brake Keypad. -12V Power Points (see below). -Whelen Siren (mounted as low as possible).
157		1	**REV-A** **ENG Lower Console Position 4:

Line	Item #	Qty	Item Description/Comments
			-United Safety Brake override switch.
158		1	**ENG Lower Console Position 5: Switch #1: Master Emergency. Switch #2: Mech Siren. Switch #3: Siren Brake. Switch #4: Blank. Switch #5: Blank. Switch #6: Blank. Switch #7: Blank.
159	30010610	1	CAB PUMP SHIFTER, ELECTRIC W/YELLOW KNOB (FOR HALE G-SERIES / WATEROUS C20 PUMP TRANSMISSION)
160	30011010	1	PUMP INTERLOCK, CONNECTED WITH ODOMETER
161	29930210	1	DELETE MAPBOOK SLOT ON FRONT BREAKER PANEL
162	29910100	1	PROGRAMMABLE LOAD MANAGER, CLASS-1 SUPERNODE II
163	30031100	1	HIGH IDLE SWITCH
164	30031771	1	12V POWER POINT, (1)
165		1	**ENG Power Point Location #1: Lower Console Position 3, Driver's corner.
166	30031802	1	12V DUAL PORT USB POWER POINTS, (2)
167		1	**ENG USB Power Point Location #1: Lower Console Position 3, Officer's corner.
168		1	**ENG USB Power Point Location #2: Lower Console Position 3, Driver's corner.
169	11040000	1	CAB ACCESSORY FUSE PANEL
170	84541540	1	POWER & GROUND STUDS, UPPER COMMAND CONSOLE
171		1	**ENG Requirements (AMPS) for Power/Ground Studs in Upper Command Console: (1) 12-volt 60-amp, direct to the battery ignition off. (1) 12-volt 30-amp switched battery first position on ignition switch. (1) 12-volt 30-amp ignition power second position on ignition switch. (1) 12-volt 125-amp ground.
172	30110000	1	VEHICLE DATA RECORDER, AKRON/WELDON
173	33510030	1	INTERIOR CAB LIGHTS, WHELEN 6" ROUND RED/CLEAR LED (2)
174	34010030	1	INTERIOR CREW LIGHTS, WHELEN 6" ROUND RED/CLEAR LED (2)
175	28010750	1	DEFROSTER, HEATER & A/C, SEVERE CLIMATE (TM-31)
176	28090003	1	HEAT TO FEET
177	28090100	1	A/C TO FACE

Line	Item #	Qty	Item Description/Comments
178	28030500	1	DEFROSTER DUCTWORK, ENTIRE WINDSHIELD
179	11031687	1	TOP HEAT/AC STORAGE, TOOL MOUNTING PLATE, 25" x 19.5"
180	38510104	1	DRIVER'S SEAT, BOSTROM SIERRA HIGH BACK AIR RIDE ABTS (DURAWEAR PLUS, LOW SEAM)
181	38320000	1	HELMET STORED IN COMPARTMENT
182	39010118	1	OFFICER'S SEAT, BOSTROM TANKER 450, ABTS SCBA (DURAWEAR PLUS, LOW SEAM)
183	39030030	1	OFFICER'S SEAT COMPT, FRONT DOOR W/LOCKING LATCH
184	38320000	1	HELMET STORED IN COMPARTMENT
185	39521188	1	CREW SEAT 1, BOSTROM TANKER 400CT, ABTS SCBA FLIP UP (DURAWEAR PLUS, LOW SEAM)
186	38320000	1	HELMET STORED IN COMPARTMENT
187	39521189	1	CREW SEAT 2, BOSTROM TANKER 400CT, ABTS SCBA FLIP UP (DURAWEAR PLUS, LOW SEAM)
188	38320000	1	HELMET STORED IN COMPARTMENT
189	39521430	1	CREW SEAT 3, BOSTROM TANKER 400CT, ABTS SCBA FLIP UP (DURAWEAR PLUS, LOW SEAM)
190	38320000	1	HELMET STORED IN COMPARTMENT
191	39521431	1	CREW SEAT 4, BOSTROM TANKER 400CT, ABTS SCBA FLIP UP (DURAWEAR PLUS, LOW SEAM)
192	38320000	1	HELMET STORED IN COMPARTMENT
193	39550200	1	SEAT COLOR, BLACK
194	39610000	5	SCBA BRACKETS, BOSTROM, SECURE ALL (5)
195	38410000	1	SEAT BELT WARNING SYSTEM, AKRON / WELDON
196	39710000	1	DOUBLE CREW SEAT COMPT, SIDE DOORS
197	39730100	1	LOCKING LATCHES FOR CREW SEAT COMPARTMENT DOORS
198	30080150	1	HD STEREO, JENSEN, AM/FM/WB/BT
199		1	**ENG HD Jensen Stereo mounted in Overhead Console Position 2.
200	84561010	1	CAMERA SYSTEM, FRC, INVIEW TRUEVIEW, SINGLE CAMERA (WIRED)
201		1	**CLAR NOTES, -Camera Mounting Location #1 = Rear of Body. -Camera Mounting Location #2 = Below Officer's Turn Signal Housing. -Camera Monitor Mounting Location = Below Overhead Console Position 3.
202	11088888	1	SPECIAL ITEM, INSTALL HAAS HA-5 SAFETY ALERTING SYSTEM

Line	Item #	Qty	Item Description/Comments
203		1	**CLAR NOTES, -Reference SPR #001-00-890177 when ordering. -Kit ID: HA-5. -Production Description: ALERT KIT, HA-5, OBU, CABLE -60 Months Cloud Subscription, (1) HA-5 Safety Cloud Service, (1) OBU & Cable. -Installed on Dog House, towards windshield, on Officer's or Driver's side, Engineering to determine best location.
PUMP & PLUMBING			
204	60012555	1	QMAX-2000 GPM 6" SUCTION SINGLE STAGE PUMP
205		1	**ENG Pump to be ordered at 2000 GPM and rated at 1500 GPM.
206	60025010	1	GEARBOX, HALE, G-SERIES, FRONT MOUNTED
207	60026000	1	PUMP PACKING, HALE
208	60031005	1	ALLOY ANODES, HALE (2)
209	60035123	1	PUMP TEST, THIRD PARTY TESTING
210	61510000	1	AUXILIARY COOLER (HEAT EXCHANGER)
211	62010002	1	STAINLESS STEEL PIPING
212	66020100	1	3" TANK TO PUMP W/CHECK VALVE
213	61720100	1	VALVE, AKRON HEAVY DUTY
214	61770120	1	ACTUATOR, VALVE, PUSH/PULL HANDLE, INNOVATIVE CONTROLS
215	73010100	1	TANK FILL 1.5"
216	61720100	1	VALVE, AKRON HEAVY DUTY
217	61770120	1	ACTUATOR, VALVE, PUSH/PULL HANDLE, INNOVATIVE CONTROLS
218	61010405	1	PRESSURE GOVERNOR, CLASS 1 TPGJ1939
219	61210410	1	INTAKE PRESSURE CONTROL, TFT A1831
220	63021100	1	6" MAIN SUCTION, LEFT SIDE
221	65030000	1	2.5" LEFT SIDE INLET
222	61720100	1	VALVE, AKRON HEAVY DUTY
223	61770100	1	ACTUATOR, VALVE, SWING HANDLE
224	60036010	1	THREADS, NST
225	63025100	1	6" MAIN SUCTION, RIGHT SIDE

Line	Item #	Qty	Item Description/Comments
226	64030000	1	2.5" RIGHT SIDE INLET
227	61720100	1	VALVE, AKRON HEAVY DUTY
228	61770100	1	ACTUATOR, VALVE, SWING HANDLE
229	60036010	1	THREADS, NST
230	70525125	1	2.5" DISCHARGE, LEFT - POSITION 1
231	61720100	1	VALVE, AKRON HEAVY DUTY
232	61770100	1	ACTUATOR, VALVE, SWING HANDLE
233	77021010	1	GAUGE, DISCH, INNOVATIVE CONTROLS 2.5"
234	61810150	1	DISCHARGE TERMINATION, 30 DEGREE ELBOW
235	60036010	1	THREADS, NST
236	70525125	1	2.5" DISCHARGE, LEFT - POSITION 2
237	61720100	1	VALVE, AKRON HEAVY DUTY
238	61770100	1	ACTUATOR, VALVE, SWING HANDLE
239	77021010	1	GAUGE, DISCH, INNOVATIVE CONTROLS 2.5"
240	61810150	1	DISCHARGE TERMINATION, 30 DEGREE ELBOW
241	60036010	1	THREADS, NST
242	71025130	1	3" DISCHARGE, RIGHT - POSITION 3
243	61720110	1	VALVE, AKRON SLOW CLOSE
244	61770100	1	ACTUATOR, VALVE, SWING HANDLE
245	77021010	1	GAUGE, DISCH, INNOVATIVE CONTROLS 2.5"
246	61810150	1	DISCHARGE TERMINATION, 30 DEGREE ELBOW
247	60036010	1	THREADS, NST
248	71025125	1	2.5" DISCHARGE, RIGHT - POSITION 4
249	61720100	1	VALVE, AKRON HEAVY DUTY
250	61770100	1	ACTUATOR, VALVE, SWING HANDLE
251	77021010	1	GAUGE, DISCH, INNOVATIVE CONTROLS 2.5"

Line	Item #	Qty	Item Description/Comments
252	61810150	1	DISCHARGE TERMINATION, 30 DEGREE ELBOW
253	60036010	1	THREADS, NST
254	72811000	1	ONE 2.5" CROSSLAY, 2.5" SWVL & TWO 2" CROSSLAYS W/1.5" SWIVEL (SPH)
255		1	**CLAR NOTES, -Crosslay Hose Load Requirement = -(1) 200' of 2.5". -(2) 200' of 1.75".
256	61720100	3	VALVE, AKRON HEAVY DUTY (3)
257	61770425	3	ACTUATOR, VALVE, ELECTRIC, AKRON 9333 (3)
258	77021010	3	GAUGE, DISCH, INNOVATIVE CONTROLS 2.5" (3)
259	60036010	3	THREADS, NST (3)
260	72910520	1	COVER, VINYL FOR CROSSLAYS (SPH)
261	72932210	1	COVER FASTENERS, METAL SNAPS
262		1	**CLAR NOTES, -Crosslay/Speedlay Cover Color = Black. -Snaps used on Front Crosslay to secure cover. -Snaps and Bungee Cords with Red Tabs on Body Crosslays.
263	61742000	1	MASTER PUMP DRAIN, MULTIPORT
264	61730005	9	DRAIN VALVES, INNOVATIVE CONTROLS, LIFT-UP (9)
265	78521445	1	WATERWAY CONTROL, 4" VALVE, AKRON 9335 ELECTRIC ACTUATOR
266	61910100	1	WATERWAY DRAIN VALVE, AKRON 1.5" PUSH/PULL CONTROL
PUMP PANEL			
267	74920210	1	SPH1 - SIDE MOUNT PUMP PANEL
268	74930500	1	PANEL FINISH, BLACK VINYL
269		1	**ENG Pump Panel Label Verbiage Standard = Yes.
270	74931000	1	ESCUTCHEON PLATES
271	74931050	1	COLOR CODING
272		1	**ENG Color Coding Standard = Yes.
273	74931210	1	PUMP MODULE FRAMEWORK, NON-PAINTED
274	74931320	1	PUMP FINISH, PAINTED BY SUTPHEN

Line	Item #	Qty	Item Description/Comments
275		1	**ENG Painted Pump = Match Frame Color.
276	74931530	1	PLUMBING FINISH, PAINTED BY SUTPHEN
277		1	**ENG Painted Plumbing = Match Frame Color.
278	75510230	1	PUMP OPERATOR LIGHTS, TECNIQ E44 LED STRIP
279	75530112	1	PUMP PANEL LIGHTS OFFICER'S SIDE, TECNIQ E44 LED STRIP
280	76010105	1	PUMP PANEL GAUGES & CONTROLS
281	60028050	1	PUMP PRIMER, TRIDENT, AIR
282	60028310	1	(1) PRIMER BUTTON - MAIN SUCTION
283	76025100	1	COMPRESSION FITTINGS ON AIR SYSTEM (CTZ PUMP MODULE)
284	76031970	1	AIR OUTLET, DRIVER'S SIDE PUMP PANEL
285	76030805	1	HALE TRV-L THERMAL RELIEF VALVE WITH LIGHT AT PUMP PANEL
286	76031900	1	AIR HORN PUSH BUTTON SWITCH ON PUMP PANEL
287		1	**CLAR NOTES, -Air Horn Push Button Location = Readily available to operator. -Push Button to be Red.
288	76510060	1	GAUGES, MASTER, INNOVATIVE CONTROLS, 4"
289	77510090	1	GAUGE, WATER LEVEL, CLASS 1, INTELLI-TANK ITL-40
290		1	**ENG Water Level Gauge Color Multi Color.
WATER TANK			
291	83525200	1	WATER TANK BRAND, UPF
292	83520205	1	WATER TANK, 300 GAL, POLY (AERIALS)
BODY			
293	80117030	1	BODY SPH-3, LEFT 56" H / RIGHT 56"H
294		1	**ENG L2/L3 and R2/R3 to be separate Compartments.
295	80029910	1	BODY SUBFRAME, SPH100
BODY COMPARTMENTS			

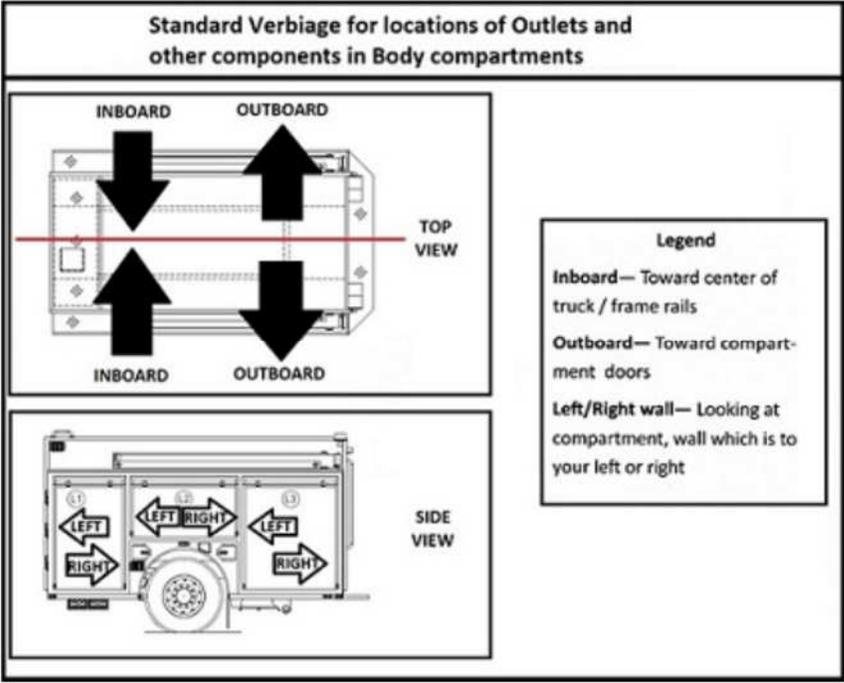
Line	Item #	Qty	Item Description/Comments
			<p style="text-align: center;">Standard Verbiage for locations of Outlets and other components in Body compartments</p>  <p>The diagram consists of three parts: a title, a top view, and a side view. The title is 'Standard Verbiage for locations of Outlets and other components in Body compartments'. The top view shows a rectangular compartment with a red horizontal line across the middle. Four large black arrows point towards the center (labeled 'INBOARD') and away from the center (labeled 'OUTBOARD'). The side view shows a compartment with a wheel at the bottom center and three sections labeled 'L1', 'L2', and 'L3'. Arrows indicate 'LEFT' and 'RIGHT' directions for each section. A legend box on the right defines the terms: 'Inboard— Toward center of truck / frame rails', 'Outboard— Toward compartment doors', and 'Left/Right wall— Looking at compartment, wall which is to your left or right'.</p>
296	81130200	1	ADJUSTABLE SHELF [L2] (1)
297	80250100	2	TURTLE TILE ON COMPT FLOOR, SHELF, TRAY, OR DRAWER [L2] (2)
298	81130200	1	ADJUSTABLE SHELF [L3] (1)
299	80250100	2	TURTLE TILE ON COMPT FLOOR, SHELF, TRAY, OR DRAWER [L3] (2)
300	81130200	1	ADJUSTABLE SHELF [L4] (1)
301	80250100	2	TURTLE TILE ON COMPT FLOOR, SHELF, TRAY, OR DRAWER [L4] (2)
302	80588888	1	SPECIAL ITEM, HANGER BAR FOR SAFETY BELTS [L5]
303	81130200	1	ADJUSTABLE SHELF [L5] (1)
304	80250100	2	TURTLE TILE ON COMPT FLOOR, SHELF, TRAY, OR DRAWER [L5] (2)
305	81130200	1	ADJUSTABLE SHELF [L6] (1)
306	80250100	2	TURTLE TILE ON COMPT FLOOR, SHELF, TRAY, OR DRAWER [L6] (2)
307	81088888	1	SPECIAL ITEM, FIXED SHELF [R1]
308		1	**ENG Shelf to be installed even with Exhaust notch.
309	80250100	1	TURTLE TILE ON COMPT FLOOR, SHELF, TRAY, OR DRAWER [R1] (1)
310	81130200	1	ADJUSTABLE SHELF [R2] (1)
311	80250100	2	TURTLE TILE ON COMPT FLOOR, SHELF, TRAY, OR DRAWER [R2] (2)

Line	Item #	Qty	Item Description/Comments
312	81130200	1	ADJUSTABLE SHELF [R3] (1)
313	80250100	2	TURTLE TILE ON COMPT FLOOR, SHELF, TRAY, OR DRAWER [R3] (2)
314	81130200	1	ADJUSTABLE SHELF [R4] (1)
315	80250100	2	TURTLE TILE ON COMPT FLOOR, SHELF, TRAY, OR DRAWER [R4] (2)
316	81130200	1	ADJUSTABLE SHELF [R5] (1)
317	80250100	2	TURTLE TILE ON COMPT FLOOR, SHELF, TRAY, OR DRAWER [R5] (2)
318	81130200	1	ADJUSTABLE SHELF [R6] (1)
319	80250100	2	TURTLE TILE ON COMPT FLOOR, SHELF, TRAY, OR DRAWER [R6] (2)
320	80250100	1	TURTLE TILE ON COMPT FLOOR, SHELF, TRAY, OR DRAWER [A1] (1)
321		1	**ENG Turtle Tile Color = Black.
322	81165705	1	UNISTRUT TRACK IN COMPTS
323	80228888	1	SPECIAL ITEM, COMPT DOORS, SPH MIXED AMDOR ROLL-UP AND HINGED
324		1	**CLAR NOTES, -L2 / L3 / R2 / R3 Compartments to be hinged painted doors. -All other Compartment Doors will be AMDOR roll-up painted. -All roll-up doors to be painted, even the trim. -Painted Job Color Red. -A1 Door will drop-down treadplate. -A1 Compartment to have bump outs for New York Roof Hooks.
325	84531110	1	COMPT LIGHTING, AMDOR LED LIGHT STRIPS, 2 PER COMPT
BODY EXTERIOR			
326	81320205	1	SPH 100 HOSEBED, ALUM FLOORING
327		1	**ENG List the Hose Bed Hose Load Req. = 900' of 5".
328	81410000	1	COVER, VINYL, MAIN HOSE BED
329	81431300	1	REAR HOSEBED COVER, VINYL
330	81440220	1	COVER FASTENERS, BLACK PLASTIC BUCKLES
331		1	**CLAR NOTES, -Hosebed Cover Color = Black. -Top Hosebed Cover to be secured using snaps. -Rear Hosebed Cover to be secured using black plastic buckles.
332	81332115	1	HOSEBED LIGHTING, SIDES, TECNIQ E44 LED LIGHT STRIPS
333	81910500	1	HANDRAILS, KNURLED STS, SPH100

Line	Item #	Qty	Item Description/Comments
334	82014500	1	STEPS, IC FOLD DOWN W/LIGHT (SPH)
335		1	**ENG Step Light Color = White.
336	82510000	1	RUB RAILS, ANODIZED ALUM
337	83010125	1	ALUMINUM TREADPLATE (SPH)
338	80290101	1	FIBERGLASS WHEEL WELL LINERS (TANDEM AERIALS)
339	80231260	1	7 SCBA CYLINDER COMPTS (TANDEM BODY)
340	80290310	7	DOOR FINISH, BRUSHED STAINLESS, SINGLE/DOUBLE SCBA COMPT (7)
341	83030605	1	REAR FENDERS, STAINLESS SMOOTH PAINTED (AERIALS)
342	89020230	1	LADDERS, ALCO-LITE (SPH) 115' 14', 16', 16', 24'-2sec, 35'-2sec & 10'F
343	89512200	1	LADDERS ENCLOSED IN HOSEBED ON BEAM (SPH)
344	89520210	1	LADDER ENCLOSURE, DIAMONDPLATE DOOR
345		1	<p>**CLAR NOTES,</p> <p>-Mounted in the Ladder Chute:</p> <p>-(1) 14' Combo Ladder.</p> <p>-(1) 24' 2-Section Ladder.</p> <p>-(2) 16' Roof Ladder.</p> <p>-(1) 35' 2-Section Ladder.</p> <p>-Mounted in Fly section of Boom:</p> <p>-(1) 10' Folding Ladder.</p> <p>-(1) Pike Pole.</p>
ELECTRICAL			
346	84550110	1	LICENSE PLATE BRACKET W/ LIGHT, LED
347	84511100	1	BODY ELECTRICAL DESCRIPTION
348	84520000	1	BACK UP ALARM, ECCO SA917
349	85010420	1	TAILLIGHTS, WHELEN M6 SERIES, LED STOP/TAIL/TURN/REVERSE, QUAD HOUSING (PAIR)
350		1	**ENG Tail Light Housing Color = Chrome.
351	85110100	1	ICC LIGHTS, LED
352	85130100	1	MARKER LIGHTS, BRITAX, FLEXIBLE, LED, PAIR, ON SIDES OF BODY, REAR CORNERS
353	85510205	1	STEP LIGHTS, LED, REAR BODY & WHELEN 2G AT PUMP PANEL
354	85710045	1	UNDERCARRIAGE GROUND LIGHTS, WHELEN 2G LED (TANDEM)

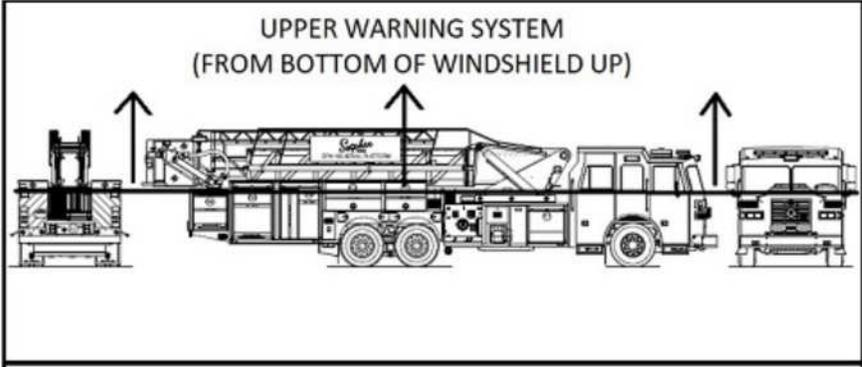
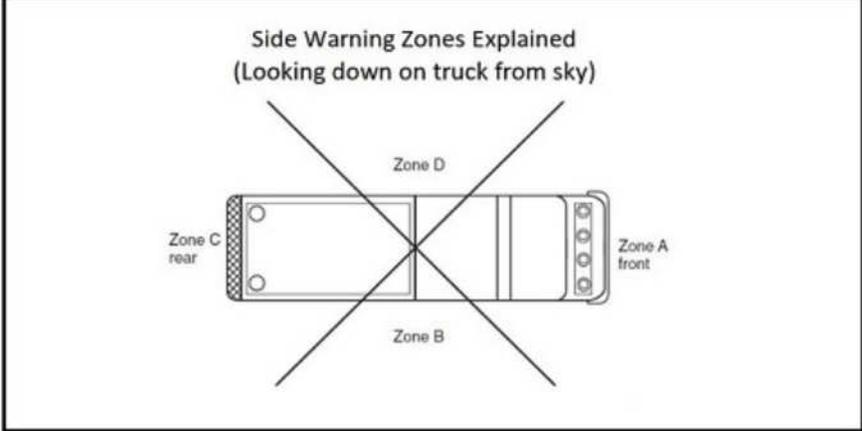
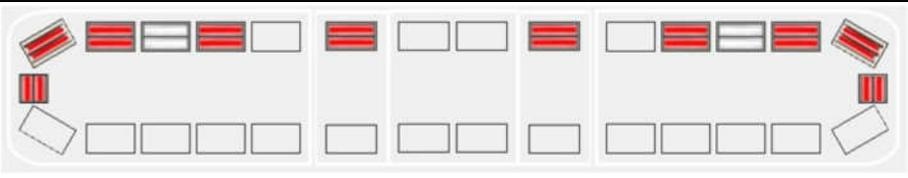
Line	Item #	Qty	Item Description/Comments
355	86528999	1	DELETE REAR WORK LIGHTS
356	86600105	1	OPTICAL WARNING SYSTEM, UPPER (SPH100)
			<p style="text-align: center;">UPPER WARNING SYSTEM (FROM BOTTOM OF WINDSHIELD UP)</p>  <p style="text-align: center;">Side Warning Zones Explained (Looking down on truck from sky)</p> 
357	86610120	1	UPPER WARNING LIGHTS, ZONE A (FRONT), WHELEN FREEDOM IV 72" LED LIGHT BAR, F4N7QLED, 12 MODULES
			
358		1	**ENG Zone A, Upper Lightbar Color / Details = Zone A (front) shall have one (1) Whelen Freedom IV 72" Model F4N7QLED light bar, with twelve (12) LED modules. The light bar shall have two (2) end red LED modules, two (2) corner red LED modules, six (6) forward-facing red LED modules and two (2) forward-facing white LED modules. The light bar shall have all clear outer lenses. The light bar shall be installed on the cab roof as far forward as possible with two (2) MK8H 5" cast aluminum risers.
359	86699999	1	UPPER WARNING LIGHTS, ZONE B (OFFICER'S SIDE), COVERED BY ZONES A & C
360	86710105	1	UPPER WARNING LIGHTS, ZONE C (REAR), WHELEN LED BEACONS, L31 (PAIR)
361		1	**ENG Zone C, Upper Rear Beacon Color/Details = Red LED / Clear lenses.
362	86810200	1	UPPER WARNING LIGHTS, ZONE C (REAR PLATFORM), WHELEN M6 LED, M6* (QTY 1)

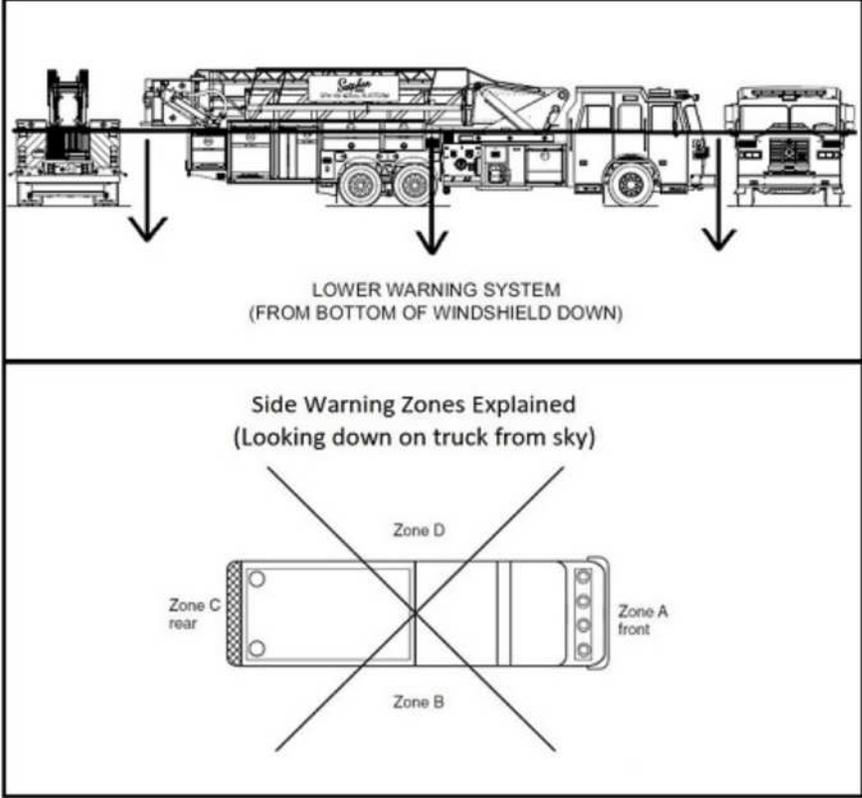
Line	Item #	Qty	Item Description/Comments
363		1	**ENG Zone C, Upper Platform Warning Light Color/Details = Red LED / Clear lenses / Chrome Flange.
364	86899999	1	UPPER WARNING LIGHTS, ZONE D (DRIVER'S SIDE), COVERED BY ZONES A & C
365	87100105	1	OPTICAL WARNING SYSTEM, LOWER (SPH100)
			 <p>LOWER WARNING SYSTEM (FROM BOTTOM OF WINDSHIELD DOWN)</p> <p>Side Warning Zones Explained (Looking down on truck from sky)</p> <p>Zone D</p> <p>Zone C rear</p> <p>Zone A front</p> <p>Zone B</p>
366	87110210	1	LOWER WARNING LIGHTS, ZONE A (FRONT), WHELEN M6 LED, M6* (QTY 4)
367		1	**ENG Zone A, Lower Warning Light Color, Lens Color, Details = Red LED / Clear lenses / Chrome Flange.
368	87811130	1	LOWER, ZONE A - MOUNTING LOCATION (DUAL HOUSINGS)
369		1	**ENG Zone A, Lower - Front, Mounting Location = (2) Warnings in top headlight housing, each side.
370	87530100	1	WARNING LIGHT FLANGES ON HEADLIGHT HOUSING FOR WHELEN M6 M6FC600 (6)
371	87210220	1	LOWER WARNING LIGHTS, ZONE B (OFFICER'S SIDE), WHELEN M6 LED, M6* (QTY 4)
372		1	**ENG Zone B, Lower Officer's Side Warning Light Color, Lens Color, Details = Red LED / Clear lenses / Chrome Flange.
373	87812140	1	LOWER, ZONE B - MOUNTING LOCATION (SL100, SLR108, SPH100)
374		1	**ENG Zone B, Lower - Officer's Side, Mounting Location = -(1) Warning light above front axle. -(1) Under the turntable area. -(1) Near the rear axle.

Line	Item #	Qty	Item Description/Comments
			-(1) Near the rear corner of the apparatus.
375	87310200	1	LOWER WARNING LIGHTS, ZONE C (REAR), WHELEN M6 LED, M6* (QTY 2)
376		1	**ENG Zone C, Lower Rear Warning Light Color, Lens Color, Details = Red LED / Clear lenses.
377	87410220	1	LOWER WARNING LIGHTS, ZONE D (DRIVER'S SIDE), WHELEN M6 LED, M6* (QTY 4)
378		1	**ENG Zone D, Lower Driver's Side Warning Light Color, Lens Color, Details = Red LED / Clear lenses / Chrome Flange.
379	87814140	1	LOWER, ZONE D - MOUNTING LOCATION (SL100, SLR108, SPH100)
380		1	**ENG Zone D, Lower - Driver's Side, Mounting Location = -(1) Warning light above front axle. -(1) Under the turntable area. -(1) Near the rear axle. -(1) Near the rear corner of the apparatus.
381	88390908	1	SCENE LIGHT, FRC SPECTRA 28K, 12V LED, BROW (1)
382		1	**CLAR NOTES, -White Bracket and Housing with Chrome Flange. -Switched in Cab, Overhead Console Position 1, "Front Scene".
383	88390912	2	SCENE LIGHT, FRC SPECTRA 20K, 12V LED, SURFACE MOUNT (2)
384		1	**CLAR NOTES, -Chrome Flange. -Mounted above Fixed Window, each side. -Switched in Cab, Overhead Console Position 1, "Left Scene" and "Right Scene".
385	88390950	2	SCENE LIGHT, FRC SPECTRA 900, 12V LED, SURFACE MOUNT (2)
386		1	**CLAR NOTES, -Chrome Flange. -Mounted on rear of body, outboard corners, high. -Switched in Cab, Overhead Console Position 1, "Rear Scene". -Wired to Reverse.
GENERATOR & ACCESSORIES			

Line	Item #	Qty	Item Description/Comments
			<p style="text-align: center;">Standard Verbiage for locations of Outlets and other components in Body compartments</p> <p style="text-align: center;">Legend</p> <p>Inboard— Toward center of truck / frame rails</p> <p>Outboard— Toward compartment doors</p> <p>Left/Right wall— Looking at compartment, wall which is to your left or right</p>
387	88230201	1	GENERATOR, SMART POWER, 6KW ER HYD, AERIALS
388		1	**ENG Switched in Cab on Transmission Shifter Pad Mode button.
389	88250425	1	CIRCUIT BREAKER PANEL WITH 16 SPACES FOR BREAKERS
390	88251120	1	BREAKER PANEL, STD LOCATION (L2)
391		1	**ENG Breaker panel to be mounted as high as possible in the compartment.
392	88250100	2	120 VOLT OUTLET W/WEATHERPROOF COVER - EACH (2)
393		1	**CLAR NOTES, -NEMA Number = 5-20 House Plug Duplex. -Outlet Locations = Mounted on Rear Jack Panels, each side.
394	88431205	1	HANNAY ECR-1616-17-18 REEL W/150' 10/3 (1)
395	88433010	1	MOUNTING OF ELEC CORD REEL IN BODY COMPT
396		1	**CLAR NOTES, -Cord Reel #1 Mounting Details: Right Outrigger Area. -Reel Motor Location #1: Right Rear. -Reel Termination: L5-20 Twist Lock.
397	88432000	1	**REV-A** AKRON FOUR-WAY RECEPTACLE BOX, WIRED TO REEL CABLE (1)
398		1	**REV-A** **CLAR NOTES, -Receptacle Box, Hardwired or Pig Tail Plug = L5-20 Twist Lock. -NEMA Numbers Receptacles= (2) L5-20 Twist Lock and (2) 5-20 House Plug Duplex.
399	88390811	1	LIGHT, FR SPECTRA, LED, SURFACE MNT, 20K LUMENS, 240V, FACE OF PLATFORM (1)

Line	Item #	Qty	Item Description/Comments
400		1	**CLAR NOTES, -Chrome Flange. -Switched at Pedestal. -Switched at Platform.
401	88390812	1	LIGHT, FR SPECTRA, LED, SURFACE MNT, 20K LUMENS, 240V, UNDER PLATFORM (1)
402		1	**CLAR NOTES, -Chrome Flange. -Switched at Pedestal. -Switched at Platform.
403	88390841	2	LIGHT, FR SPECTRA, LED, TELE, 20K LUMENS, 240V, TURNTABLE (2)
404		1	**CLAR NOTES, -White Housing and Chrome Flange. -Switched at Head.
405	88390843	2	LIGHT, FR SPECTRA, LED, TELE, 20K LUMENS, 240V, SPH PLATFORM (2)
406		1	**CLAR NOTES, -White Housing and Chrome Flange. -Switched at Head.
AERIAL			
407	10040610	1	MODEL SPH100, AERIAL COMPONENTS
408	94020236	1	AERIAL TOWER ASSEMBLY, SPH100
409	93918888	1	SPECIAL ITEMS, INTEGRATED JACK PADS ON OUTRIGGERS
410	93918888	1	SPECIAL ITEM, DELETE REMOVABLE PIN IN OUTRIGGERS
411	94020316	1	TURNTABLE ACCESS, LOWER LEFT, STAINLESS STEEL
412		1	**CLAR NOTES, -Special Ladder to be installed for Integrated Jack Pads. -Proximity sensor added for ladder to show if it is stowed or not. -Sensor to be tied to Chassis Indicators in Overhead Console Position 4. -Reference HS-7334 Demo 527.
413	94020340	1	TURNTABLE ACCESS, UPPER LEFT, LADDER
414	94020360	1	TURNTABLE ACCESS, UPPER RIGHT, FOLDING STEPS
415	94020250	1	INTERLOCK SYSTEM
416	94020260	1	ROTATION LIMITING SYSTEM & SMART BOOM WARNING SYSTEM
417	94020265	1	ROTATION LIMITING ALARM, FLOYD BELL US-09-515-S
418	94020272	1	HYDRAULIC SYSTEM - SPH100
419	94020900	1	12 VOLT AUXILIARY HYDRAULIC POWER

Line	Item #	Qty	Item Description/Comments
420	94020286	1	PEDESTAL CONTROLS, PROPORTIONAL TYPE, SPH100
421	94021212	1	BOOM ASSEMBLY - SPH100
422	94020465	1	AERIAL SPOT LIGHTS – (2) FIRETECH FT-WL-X-5-S-B, LED (SP95, 100, 110, SPH)
423	94021326	1	LADDER SPH 100 HIGH RAIL, LOW PROFILE AT TURNTABLE - CABLE TRACK
424	94020490	1	LADDER LIGHTING SYSTEM, FIRETECH FT-WL-2000-S-B, LED (SP95, 100, 110, SPH)
425		1	**ENG Ladder Lighting Color = Blue.
426	94021337	1	HYDRAULIC CYLINDERS - SPH 100
427	94021344	1	AERIAL TOWER WATERWAY - 110 & SPH 100
428	94021027	1	OUTRIGGER GROUND JACKS, MANUAL CONTROL, SPH100
429	94021090	1	AERIAL JACKS ALARM, ECCO DT500
430	94028888	1	SPECIAL ITEM, OUTRIGGER DISPLAY INTEGRATED WITH JACK CONTROLS
431	94021165	1	**REV-A** OFFICER'S SIDE AREA, REAR OF OUTRIGGER, CORD REEL COMPARTMENT W/DOUBLE HINGED DOOR
432	94021340	1	OPERATIONAL TEST - AERIAL PLATFORMS
433	94040052	1	LADDER TEST, THIRD PARTY TESTING
434	94210016	1	4-DOOR PLATFORM, SPH
435	94210145	1	PLATFORM DOOR SKIN, FORWARD FACING, DIAMONDPLATE (SPH)
436	94210156	1	PLATFORM DOOR SKIN, REARWARD FACING, SMOOTH ALUMINUM (SPH)
437	94210014	1	PLATFORM ACCESS LADDER
438	94210318	1	PLATFORM BOOM CONTROLS, PROPORTIONAL TYPE, SPH/SPI112
439	94210342	1	PLATFORM CONTROL COVER, DIAMONDPLATE
440	94210280	1	DELETE PLATFORM SPOT LIGHT
441	94210350	1	120 VOLT OUTLET IN PLATFORM
442		1	**ENG Nema Number = L5-20 Twist-Lock.
443	94210802	1	75 GPM WATER CURTAIN FOR SPH 100 or SPI112
444	94210705	1	YOKE OUTLETS - SPH100

Line	Item #	Qty	Item Description/Comments
445	94210512	1	MONITOR, DS AKRON 3482 STREAM MASTER2, ELECTRIC, 1250 GPM W/AKRON 5177 ELECTRIC NOZZLE
446	94210511	1	MONITOR, OS, AKRON 3483 STREAM MASTER2, MANUAL 1250 GPM
447	94210675	1	NOZZLE, OS, AKRON 2499 & 3488 PIPE
448	94210997	1	INTERCOM SYSTEM, FRC ACT 2-STATION
449	94211100	1	PLATFORM AIR SYSTEM W/ 4500 PSI DOT AIR TANK
450	94212500	1	BREATHING AIR ALARM, FLOYD BELL TUHC-V88R-930-Q
451	94270510	1	BREATHING AIR TANK LOCATION, TURNTABLE, OFFICER'S SIDE
452	94210017	1	PARAPET LADDER, SPH100
453	94280150	1	STOKES ARMS, SPH100 PLATFORM
454	94295001	1	SINGLE LIFTING EYE, 800 LB.
PAINT & FINISH			
455	89910000	1	CORROSION REDUCTION PROGRAM (SPECS)
456	90010030	1	STAINLESS PAINT SCHEME - CORP AERIALS
457	90030007	1	TWO TONE CAB
458	90029910	1	PAINT BREAK #1 - BOTTOM OF WINDSHIELD
			
459		1	**ENG Upper Color for Two Tone Paint = White.
460		1	**ENG Lower Color for Two Tone Paint = Red.
461	90030159	1	PAINT FRAME RAILS, FUEL BEAM, BODY REAR DROP & LOWER AERIAL COMPONENTS - BLACK (TANDEM)
462	90030190	1	TEXTURED FRAME RAIL COATING

Line	Item #	Qty	Item Description/Comments
463	90030031	1	PAINT, TURNTABLE, SIDE PLATES & LIFT CYLINDER SILVER
464	90030033	1	PAINT, LADDER SHEAVE BEAMS, EXT CYLINDER & YOKE SILVER
465	90510100	1	LETTERING, NOT PROVIDED
466	90530305	1	BASIC 22KT GOLD FIRE DEPT EMBLEMS (Pair)
467	90610210	1	6" SCOTCHLITE STRIPE AROUND TRUCK (TANDEM)
468	90630405	1	MITER EDGED "Z" STRIPE
469	90630110	2	1" SCOTCHLITE STRIPE ABOVE OR BELOW - EACH (TANDEM) (2)
470	90681120	1	CHEVRON STRIPING, REAR BODY OUTBOARD, REFLEXITE (Aerial Platforms)
471		1	**ENG Chevron Striping, Rear Body Color = #030 Red Transparent & #L2 Fluorescent Lime.
472	90681420	1	CHEVRON STRIPING, REAR PLATFORM OUTBOARD, REFLEXITE
473		1	**ENG Chevron Striping, Rear of Platform Color = #030 Red Transparent & #L2 Fluorescent Lime.
474	90710075	1	BOOM SIGN, APPROX 88" X 26"
475		1	**ENG State Boom Sign Paint Color = White.
476	90720120	1	10" LETTERING FOR BOOM SIGN
EQUIPMENT			
477	91010000	1	MISC EQUIP - (1) PINT TOUCH-UP PAINT, STAINLESS STEEL NUTS & BOLTS
478	91030702	1	ZIAMATIC SAC-44 FOLDING WHEEL CHOCKS (PAIR) MTD IN REAR LADDER ACCESS AREA (SPH)
479		1	**ENG Wheel Chock Mounting Locations = Stored in rear ladder access area.
480	89050100	1	PIKE POLE STORAGE TUBES, (3) EA SIDE
COMPLETION & WARRANTY			
481	99010000	1	MANUALS (1-PRINTED & 1-USB) WITH DVD
482	99031110	1	DELIVERY, AERIAL APPARATUS
483	99520210	1	WARRANTY, ONE YEAR - AERIALS (DUBLIN)
484	99521100	1	WARRANTY, FRAME, LIFETIME
485	99521200	1	WARRANTY, CAB STRUCTURAL, 10 YR.
486	99521300	1	WARRANTY, BODY STRUCTURAL, 10 YR.

Line	Item #	Qty	Item Description/Comments
487	99521400	1	WARRANTY, PAINT, 10 YR.
488	99521500	1	WARRANTY, AERIAL MECHANICAL, 2 YR.
489	99521600	1	WARRANTY, AERIAL STRUCTURAL, 30 YR.
490	99521900	1	WARRANTIES, MAJOR VENDOR COMPONENTS